

CABLES OMITTED FOR CLARITY

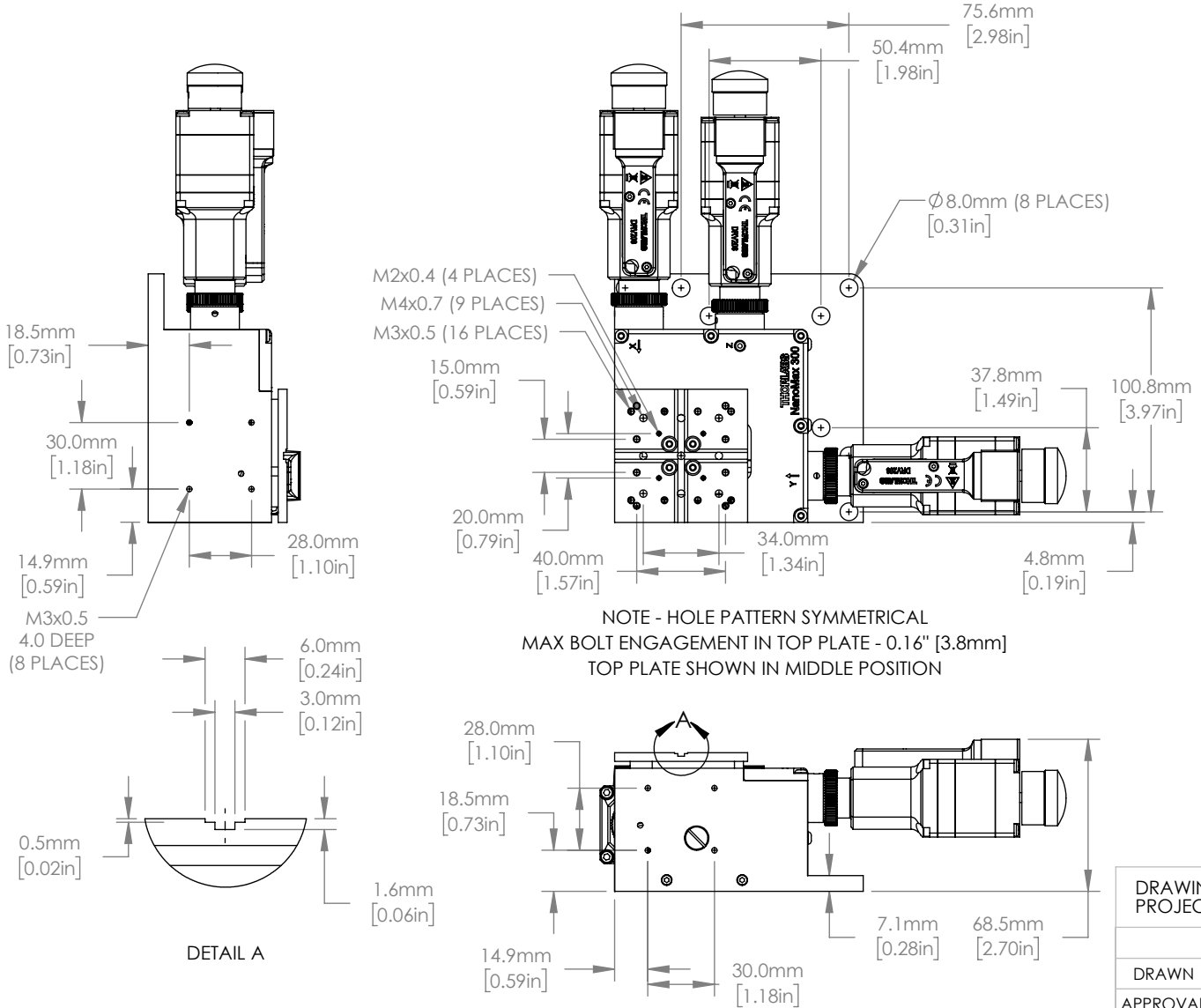

NOTE - HOLE PATTERN SYMMETRICAL  
 MAX BOLT ENGAGEMENT IN TOP PLATE - 0.16" [3.8mm]  
 TOP PLATE SHOWN IN MIDDLE POSITION

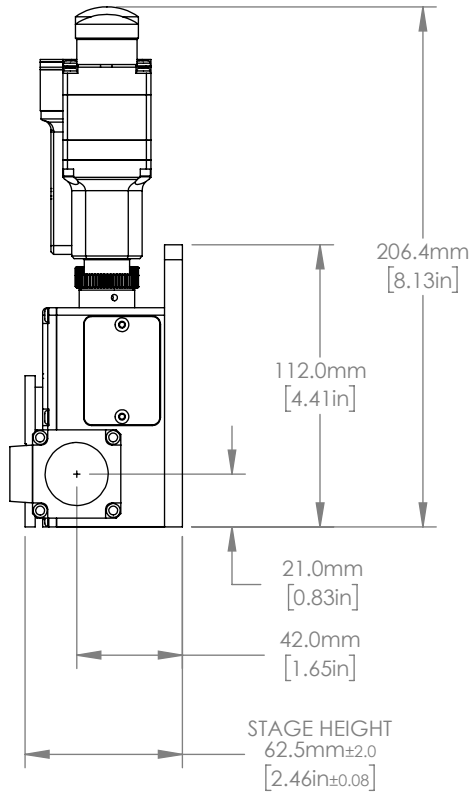

FOR INFORMATION ONLY  
 NOT FOR MANUFACTURING PURPOSES

DRAWING PROJECTION			<b>THORLABS</b> www.thorlabs.com	
NAME	DATE	3-AXIS NANOMAX STAGE, STEPPER MOTORS, METRIC		
DRAWN	IG	01/NOV/18	MATERIAL	REV A
APPROVAL	DC	01/NOV/18	N/A	
COPYRIGHT © 2018 BY THORLABS			ITEM #	APPROX WEIGHT
VALUES IN PARENTHESIS ARE CALCULATED AND MAY CONTAIN ROUND OFF ERRORS			MAX383/M	2.8 kg